

## HORIZONTAL CONTINUOUS CASTING WITH INDUCTION FURNACE

BEST SOLUTION FOR FAST CHANGE OF ALLOYS  
PRECISE TEMPERATURE CONTROL  
HOMOGENEOUS TEMPERATURE  
HIGH ENERGY EFFICIENCY



HORMESA HAS DEVELOPED FOR ITS CONTINUOUS CASTING PLANTS, FURNACES WITH INDUCTION HEATING FOR HOLDING OF LIQUID METAL DURING CASTING, OR FOR MELTING AND HOLDING IN THE SAME UNIT.

PERFECT FOR FAST CHANGE OF ALLOYS, PRECISE TEMPERATURE CONTROL, AND HOMOGENEOUS TEMPERATURE DUE TO THE MOVEMENT IN THE METAL CAUSED BY THE INDUCTION.

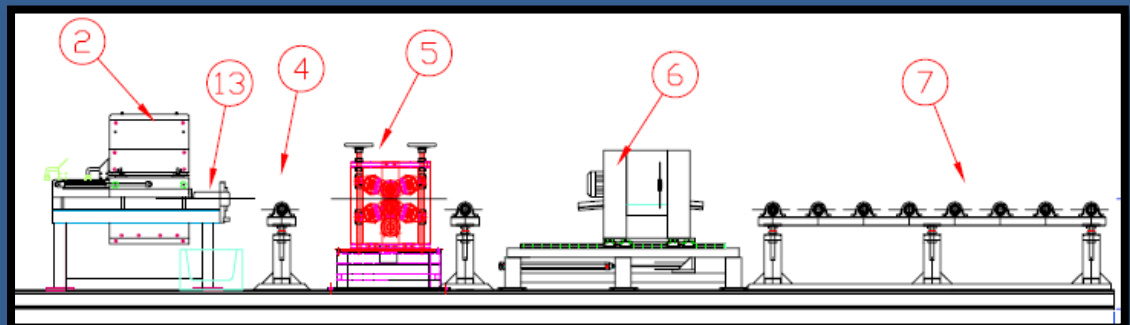
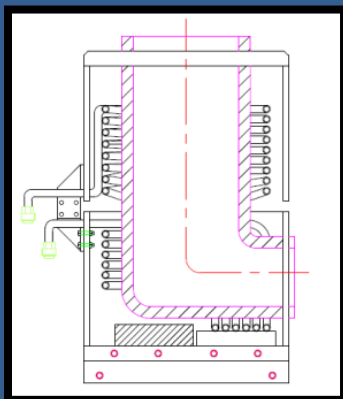

LAYOUT OF A PLANT WITH INDUCTION FURNACE FOR HORIZONTAL CONTINUOUS CASTING

IN HORMESA'S LABORATORY WE ARE CONTINUOUSLY DOING TESTS TO IMPROVE CASTING PROCESS AND TRYING THE CASTING OF DIFFERENT ALLOYS.

THE CUSTOMER CAN ASK THE TEST OF THE CASTING OF AN SPECIFIC ALLOY BEFORE PURCHASING TO BE SURE ABOUT EACH PROJECT ACCOMPLISHMENT .



## PROJECT TURN KEY MANAGEMENT

AVAILABLE ON REQUEST FROM HORMESA

- PROJECT DEFINITION CONSULTANCY.
- SPECIFICATION OF EQUIPMENT AND SCOPE OF SUPPLY.
- COORDINATION OF EQUIPMENT PURCHASE, DELIVERY, INSTALLATION, START UP AND COMMISSIONING.
- COORDINATION OF TECHNICAL SERVICE SUPPORT.

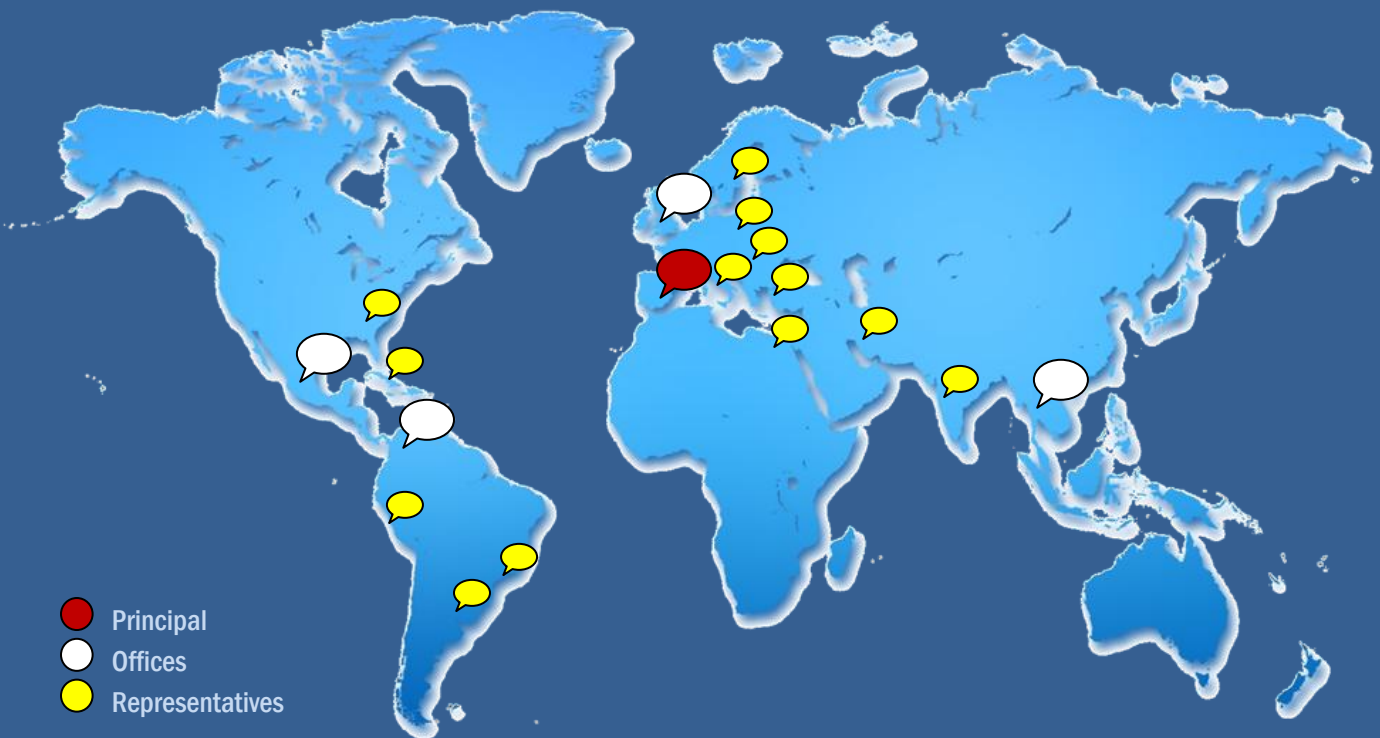

## CONTINUOUS CASTING SOLUTIONS

SERVICE 24/7



Las Marineras, 13-17 E-28.864 Ajalvir-Madrid-España

T° +34 918 874 039

Fax. +34 918 844 382

e-Mail : [hormesa@hormesa.com](mailto:hormesa@hormesa.com)

[www.hormesa.com](http://www.hormesa.com) - [www.conticast.com](http://www.conticast.com)